

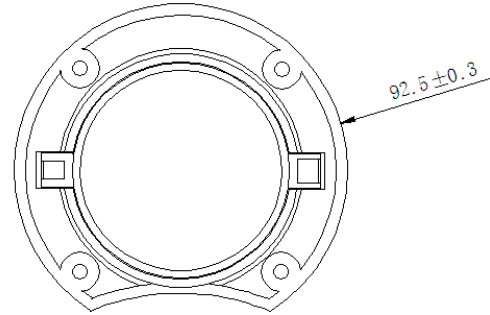

SPEAKER MODEL : 93R-TA

DESCRIPTION SPEAKER

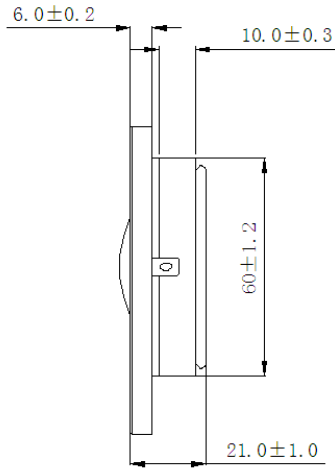

SPEAKERSPECIFICATION

Outer Dimensions	92.5mm(See attached drawing)
Rated (Max.)Input	20W (40W)
Voice Coil Imp.	6± 0.9 Ω (2000 Hz 1 V)
Lowest Resonance Frequency (fo)	1100± 220 Hz (1 V)
Sound Pressure Level	87 ± 2 dB (1 w1m) at(3.0)(5.0)(7.0)(9.0)KHZ
Frequency Response Deviation	FO 880Hz ~ 20KHz max -10 dB
Operating temperature	-20 +70 ± 2 °C Hours 2 0 ~ 5 0 % R.H.
Load test	White noise at 40 W 48 hours
Weight	288 g

Other non-stipulated matters are based on CNS4784 4785 4786 based on JIS.C. 5530 5531

FREQUENCY RESPONSE CURVE^(7*18)

