

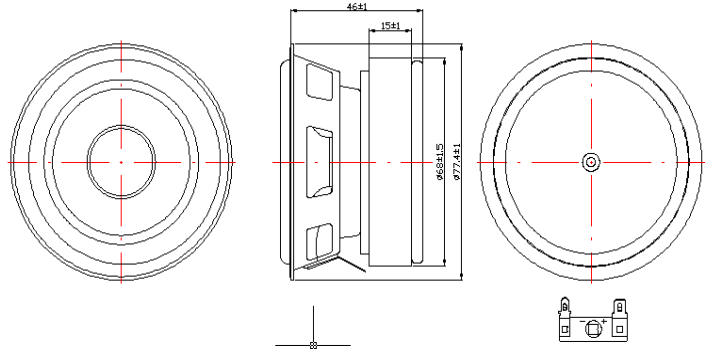

# SPEAKER MODEL :76RR-TA1

## DESCRIPTION SPEAKER



## SPEAKER SPECIFICATION

Outer Dimensions	76mm(See attached drawing)		
Rated (Max.)Input	10 W (15W)		
Voice Coil Imp.	8 ± 1.2	Ω	( 400 Hz 1 V )
Lowest Resonance Frequency ( fo )	110 ± 22	Hz	( 1 V )
Sound Pressure Level	90 ± 2	dB	( 0.1 w 0.5 m ) at(0.6)(0.8)(1.0)(1.2)KHZ
Frequency Response Deviation	FO Hz ~	20 KHz max	-10 dB
Operating temperature	-20 +50 ± 2	°C	Hours 2 0 ~ 5 0 % R.H.
Load test	White noise at	10 W	48 hours
Weight	460 g		

Other non-stipulated matters are based on CNS4784 4785 4786 based on JIS.C. 5530 5531

## FREQUENCY RESPONSE CURVE<sup>(7\*18)</sup>

