

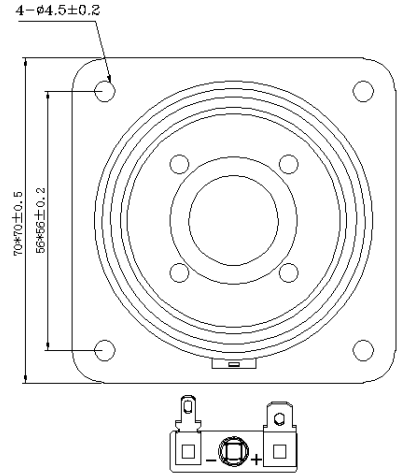

SPEAKER MODEL : 70S-A-TA

DESCRIPTION SPEAKER

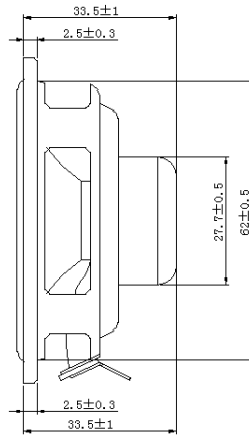

SPEAKERSPECIFICATION

Outer Dimensions	70*70mm(See attached drawing)		
Rated (Max.)Input	10W (15W)		
Voice Coil Imp.	8 ± 1.2 Ω (700 Hz 1 V)		
Lowest Resonance Frequency (fo)	115 ± 23 Hz (1 V)		
Sound Pressure Level	83± 2 dB (1 w 1m) at(0.4)(0.6)(0.8)(1.0)KHZ		
Frequency Response Deviation	FO 90 Hz ~ 20 KHz max -10 dB		
Operating temperature	-20 +70 ± 2 °C	Hours	2 0 ~ 5 0 % R.H.
Load test	White noise at 15W 48 hours		
Weight	80 g		

Other non-stipulated matters are based on CNS4784 4785 4786 based on JIS.C. 5530 5531

FREQUENCY RESPONSE CURVE^(7*18)

