

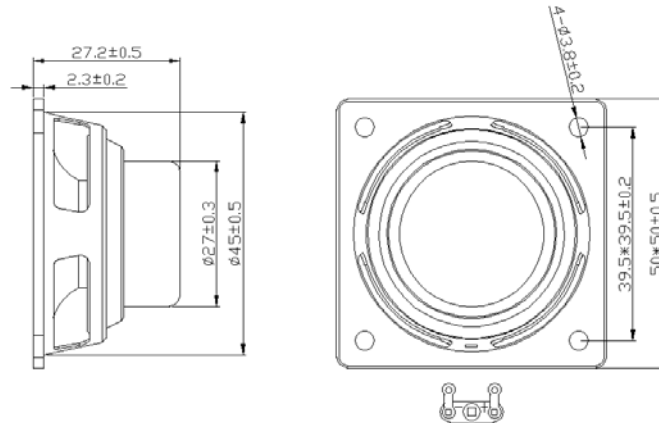

SPEAKER MODEL : 50S-A-TA

DESCRIPTION SPEAKER



SPEAKERSPECIFICATION

Outer Dimensions	50*50mm(See attached drawing)
Rated (Max.)Input	3W (5W)
Voice Coil Imp.	8 ± 1.2 Ω (850 Hz 1 V)
Lowest Resonance Frequency (fo)	160 ± 32 Hz (1 V)
Sound Pressure Level	86 ± 2 dB (1 w 0.5m) at(0.4)(0.6)(0.8)(1.0)KHZ
Frequency Response Deviation	FO 130 Hz ~ 20 KHz max -10 dB
Operating temperature	-20 +70 ± 2 °C Hours 2 0 ~ 5 0 % R.H.
Load test	White noise at 5 W 48 hours
Weight	52 g

Other non-stipulated matters are based on CNS4784 4785 4786 based on JIS.C. 5530 5531

FREQUENCY RESPONSE CURVE^(7*18)

