

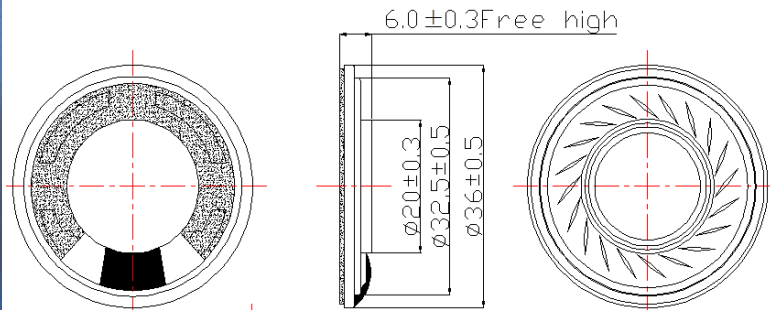

# Micro SPEAKER MODEL :36R-C

## DESCRIPTION SPEAKER



## SPEAKER SPECIFICATION

Outer Dimensions	36 mm(See attached drawing)		
Rated (Max.)Input	2.0W (3.0W)		
Voice Coil Imp.	8 ± 1.2	Ω	( 1000 Hz 1 V )
Lowest Resonance Frequency ( fo )	750 ± 150	Hz	( 1 V )
Sound Pressure Level	94 ± 2	dB	( 0.1w 0.1 m ) at(1.0)(1.2)(1.5)(2.0)KHZ
Frequency Response Deviation	FO Hz ~	20 KHz max	-10 dB
Operating temperature	-20 +50 ± 2	°C	Hours 20 ~ 50 % R.H.
Load test	White noise at 2.0 W 48 hours		
Weight	<b>12.0 g</b>		

Other non-stipulated matters are based on CNS4784 4785 4786 based on JIS.C. 5530 5531

## FREQUENCY RESPONSE CURVE<sup>(7\*18)</sup>

