

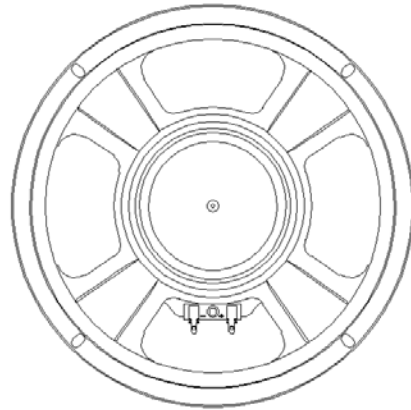

SPEAKER MODEL : 205R-TA

DESCRIPTION SPEAKER

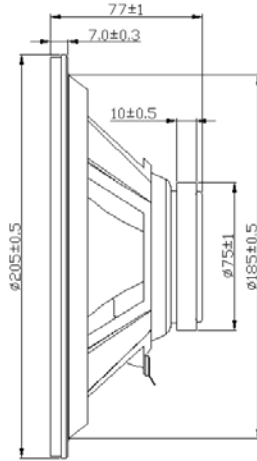

SPEAKERSPECIFICATION

Outer Dimensions	205mm(See attached drawing)
Rated (Max.)Input	25W (40W)
Voice Coil Imp.	4± 0.6 Ω (200 Hz 1V)
Lowest Resonance Frequency (fo)	90± 13 Hz (1 V)
Sound Pressure Level	90 ± 2 dB (1 w 1m) at(0.3)(0.4)(0.5)(0.6)KHZ
Frequency Response Deviation	FO 650Hz ~ 20KHz max -10 dB
Operating temperature	-20 +70 ± 2 °C Hours 2 0 ~ 5 0 % R.H.
Load test	White noise at 40 W 48 hours
Weight	640 g

Other non-stipulated matters are based on CNS4784 4785 4786 based on JIS.C. 5530 5531

FREQUENCY RESPONSE CURVE^(7*18)

