

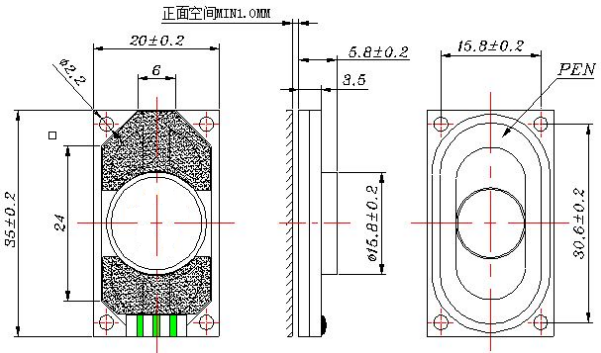

# Micro SPEAKER MODEL : 2035L-A-IP67-AS

## DESCRIPTION SPEAKER



## SPEAKER SPECIFICATION

Outer Dimensions	20*35 mm(See attached drawing)		
Rated (Max.)Input	1.5 W (2W)		
Voice Coil Imp.	8 ± 1.2	Ω	( 1000 Hz 1 V )
Lowest Resonance Frequency ( fo )	850 ± 170	Hz	( 1 V )
Sound Pressure Level	91 ± 2	dB	( 0.1 w 0.1 m ) at(1.0)(1.2)(1.5)(2.0)KHZ
Frequency Response	FO Hz ~	20 KHz max	-10 dB
Operating temperature	-20 +50 ± 2	°C	Hours 2 0 ~ 5 0 % R.H.
Load test	White noise at	1.0 W	48 hours
Weight	4.4	g	

Other non-stipulated matters are based on CNS4784 4785 4786 based on JIS.C. 5530 5531

## FREQUENCY RESPONSE

URVE<sub>(7\*18)</sub>

