

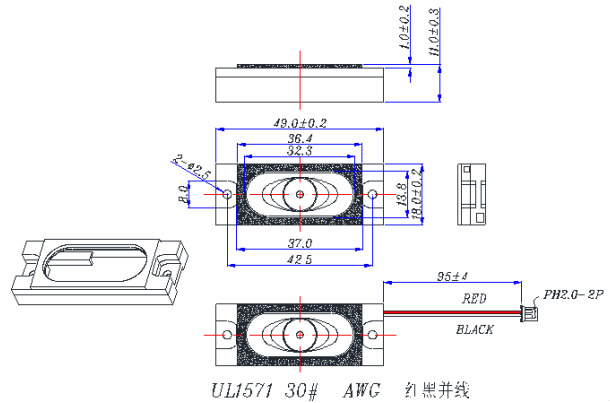

Micro SPEAKER MODEL : 1635L-BOXL(18W49)-AS

DESCRIPTION SPEAKER



SPEAKER SPECIFICATION

Outer Dimensions	18*49 mm(See attached drawing)		
Rated (Max.)Input	1.0 W (2.0W)		
Voice Coil Imp.	8 ± 1.2	Ω	(1000 Hz 1 V)
Lowest Resonance Frequency (fo)	1500 ± 300	Hz	(1 V)
Sound Pressure Level	96 ± 2	dB	(0.1 w 0.1 m) at(1.0)(1.2)(1.5)(2.0)KHZ
Frequency Response Deviation	FO Hz ~ 20 KHz max -10 dB		
Operating temperature	-20 +50 ± 2	°C	Hours 20 ~ 50 % R.H.
Load test	White noise at 1.0 W 48 hours		
Weight	6.4 g		

Other non-stipulated matters are based on CNS4784 4785 4786 based on JIS.C. 5530 5531

FREQUENCY RESPONSE CURVE^(7*18)

