

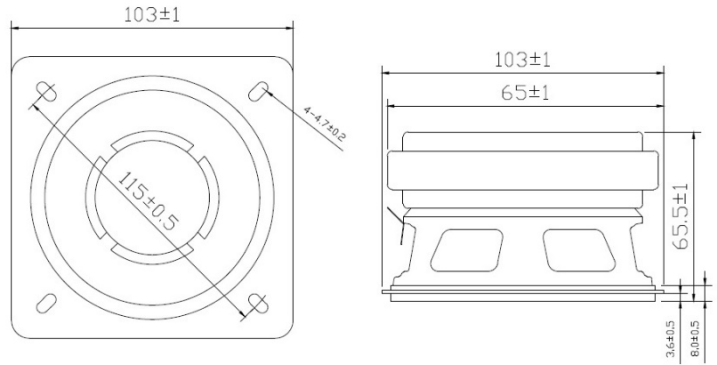

# SPEAKER MODEL : 103SR-TWO

## DESCRIPTION SPEAKER



## SPEAKER SPECIFICATION

Outer Dimensions	103mm(See attached drawing)
Rated (Max.) Input	15W ( 20 W)
Voice Coil Imp.	$8 \pm 1.2 \ \Omega$ ( 350 Hz 1 V )
Lowest Resonance Frequency ( fo )	$92 \pm 18$ Hz ( 1 V )
Sound Pressure Level	$90 \pm 2$ dB ( 1 w 0.5 m ) at(0.6)(0.8)(1.0)(1.2)KHZ
Frequency Response Deviation	FO Hz ~ 20 KHz max -10 dB
Operating temperature	-20 +70 $\pm 2$ °C Hours 2 0 ~ 5 0 % R.H.
Load test	White noise at 15 W 48 hours
Weight	518 g

Other non-stipulated matters are based on CNS4784 4785 4786 based on JIS.C. 5530 5531

## FREQUENCY RESPONSE CURVE<sup>(7\*18)</sup>

